



**TELEDYNE INSTRUMENTS**  
*Advanced Pollution Instrumentation*  
A Teledyne Technologies Company

MODEL **454**

# Process Ozone Monitor



- ▶▶ **Ranges 0-5% w/w to 0-25% w/w**
- ▶▶ **DIN panel mount**
- ▶▶ **High visibility, 4-digit display**
- ▶▶ **Temperature and pressure compensation**
- ▶▶ **Units in % w/w or g/Nm<sup>3</sup>**
- ▶▶ **Narrow bandwidth detector eliminates need for UV filters**
- ▶▶ **Analog and RS232/485 outputs**
- ▶▶ **Status LEDs to monitor performance**
- ▶▶ **316 stainless steel cell**

The Model 454 is a microprocessor based gas monitor for measuring mid to high concentrations of ozone in oxygen or air. Available in a standard DIN panel mount configuration with a 4-digit LED display, the compact design provides ease of mounting and installation.

The 454 Series is available in full scale ranges from 0-5% w/w to 0-25% w/w, and is factory calibrated in accordance with International Ozone Association standards. The measurement principle is based on the absorption of UV light at 254nm. As the sample containing ozone flows through the absorption cell, it is exposed to UV light at the 254nm wavelength. The amount of absorption by ozone is measured by a narrow bandwidth UV detector.

A reference detector measures the lamp output to compensate for changes in light intensity. This method, using a narrow spectrum UV source and a narrow bandwidth detector, provides excellent performance and stability without requiring additional UV filters.

The 454 Series' temperature and pressure compensation normalizes readings to weight/volume. A front panel keypad displays concentration or cell pressure, while LEDs indicate monitoring status. The units employ a state-of-the-art microprocessor design to provide accurate, dependable monitoring of the ozone process.



# MODEL 454 Process Ozone Monitor

## Specifications

Ranges:	0 - 5, 0 - 10, 0 - 15, 0 - 20% w/w, 0 - 25% w/w; 0 - 25, 0 - 100, 200, 300, 400 g/Nm <sup>3</sup>	Display:	4-digit LED readout
Pressure & Temp Compensation:	Standard	Analog Outputs:	0-5V full scale; 4-20mA or 0-20mA isolated outputs optional
Cell Pressure:	7 to 30 psia	Zero Calibration:	Front panel keypad, contact closure input
Proof Pressure:	100 psig	Digital Outputs:	Sensor OK, Lamp Low, Cell Dirty, Invalid Reading, (Opto-isolated)
Accuracy:	1% of full scale	Serial Outputs:	RS232 or RS485
Repeatability:	0.5% of full scale	Dimensions (HxWxD):	3.83" (97 mm) x 7.61" (193 mm) x 7.63" (194 mm)
Response Time:	< 30 seconds to 95%	Weight:	4.0 lbs (1.8 kg)
Zero Drift:	1% full scale/month (non-cumulative)		
Temperature Range:	5° to 45°C		
Wetted Materials:	316 Stainless Steel, PTFE, Sapphire, AlO <sub>3</sub>		
Fittings:	1/4" stainless steel		
Flow:	0.5 to 2.0 LPM		
Power:	90-265VAC, 50/60Hz		

## Schematic

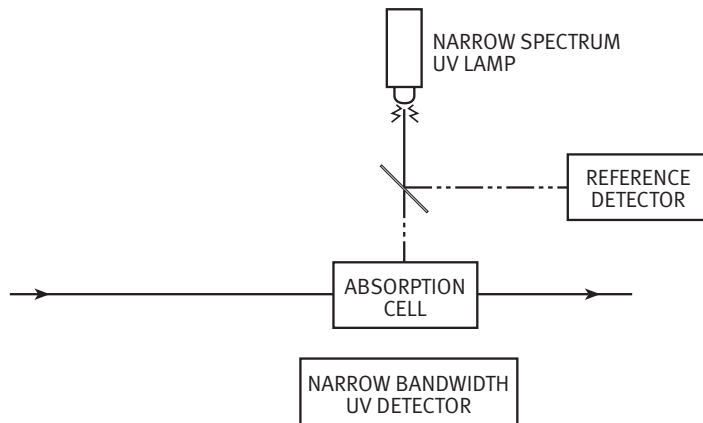

## How to Order

### Model 454 Process Ozone Monitor includes:

- Standard DIN panel mount housing
- External Ozone Destructor
- Wetted materials: 316SS, PTFE, sapphire
- 1/4" SS compression fittings
- RS485/232 interface
- Analog output
- Temperature and pressure compression

### Standard ranges (specify):

- |                                    |  |
|------------------------------------|--|
| <input type="checkbox"/> 0-5% w/w  | <input type="checkbox"/> 0-25 g/Nm <sup>3</sup>  |
| <input type="checkbox"/> 0-10% w/w | <input type="checkbox"/> 0-50 g/Nm <sup>3</sup>  |
| <input type="checkbox"/> 0-15% w/w | <input type="checkbox"/> 0-100 g/Nm <sup>3</sup> |
| <input type="checkbox"/> 0-20% w/w | <input type="checkbox"/> 0-200 g/Nm <sup>3</sup> |
| <input type="checkbox"/> 0-25% w/w | <input type="checkbox"/> 0-300 g/Nm <sup>3</sup> |
|                                    | <input type="checkbox"/> 0-400 g/Nm <sup>3</sup> |

### Options:

- External particulate filter
- Isolated 0-20mA or 4-20mA output

Specifications subject to change without notice. M454/3.08



**TELEDYNE INSTRUMENTS**  
Advanced Pollution Instrumentation

A Teledyne Technologies Company

9480 Carroll Park Drive ■ San Diego, CA 92121-5201

Ph. 858-657-9800 Fax 858-657-9816

Email [api-sales@teledyne.com](mailto:api-sales@teledyne.com)

For more information about the Teledyne API family of monitoring instrumentation products, call us or visit our website at

[www.teledyne-api.com](http://www.teledyne-api.com)

